

## 2/2-way Angle-Seat Control Valve with stainless steel design for media up to +185°C. DN 15-65

- Excellent combination of good control characteristic and high flow rates
- High cycle life
- Clean design for optimal use in hygienic environment



Type 2300 weld can be combined with...



**Type 8692/8693**  
Positioner / Process Controller TopControl



**Type 8694**  
Positioner TopControl Basic



**Type 8696**  
Positioner TopControl Basic



**Type 8792/93**  
SideControl Remote version

In line with Bürkert's philosophy for modular valves and sensors the construction of the 2300 angle-seat valve fulfils tough criteria for process environments. Unrivalled cycle life and sealing integrity is guaranteed by the proven self adjusting spindle packing with V-seals.

The parabolic trim results in a flow characteristic approximately 35% larger than conventional control valves. It is available in either stainless steel on stainless steel or with a durable PTFE seal for tight shut-off.

The design enables the easy integration of automation modules whether they are digital electropneumatic positioner or process controller.

The fully integrated system has a compact and smooth design, integrated pneumatic lines, IP65/67 protection class and superior chemical resistance.

This system has been engineered for reliable accurate control in applications where high flow rate is an advantage.

Technical data	
<b>Orifice</b>	DN15 to 65
<b>Port connections</b>	EN ISO 1127, DIN 11850 R2, ASME BPE, SMS 3008, BS 4825
Weld acc. to	
Threaded port and clamp - see separate datasheets	
<b>Body material</b>	Stainless steel 316L
<b>Actuator material</b>	PPS Stainless steel 1.4561 (316Ti)
Actuator Cover	
<b>Plug sealing</b>	PTFE/St.st. (PTFE/stainless steel) and St.st./St.st. (stainless steel/stainless steel)
<b>Seat leakage IEC 534-4/EN 1349</b>	Shut-off class III and IV for St.st./St.st. Shut-off class VI for PTFE/St.st.
<b>Medium</b>	Water, alcohol, oils, fuels, hydraulic fluids, salt solution, alkali solutions, organic solvents, steam
<b>Viscosity</b>	max. 600 mm <sup>2</sup> /s
<b>Spindle packing</b>	PTFE V-seals with spring compensation
<b>Medium temperature</b>	-10 to +185 °C (max. +130°C for PTFE/St.st. sealing)
<b>Ambient temperature</b>	0 to +55 °C (when used with positioner or process controllers) 0 to +80 °C (remote version)
<b>Control medium</b>	Compressed air
<b>Relevant pilot pressure for circuit function A</b>	Port size DN 15 to 50 5,5 to 7 bar Port size DN 65 5,6 to 7 bar
<b>Pilot air ports</b>	Push-in connector for external ø 6 mm or 1/4" tube
<b>Installation</b>	As required, preferably with actuator in upright position
<b>Surface Finish</b>	standard Ra, internal ≤ 3.2 µm on request int. Ra ≤ 0.6 µm mechanical polished int. Ra ≤ 0.6 µm electro polished

### Content



#### Valve specifications

##### Type 2300 weld

Technical data & ordering info. p. 1-6



#### System Continuous ELEMENT

##### Type 8802-YG

Ordering info. & technical data p. 7-12

#### Request for quotation

##### Type 8802-YG

p. 13

## Technical data Type 2300. continued

 $K_{vs}$  values water/pressure

Orifice [mm]	Actuator size [mm]	$K_{vs}$ value water (m <sup>3</sup> /h)	Minimum pilot pressure [bar] *	Operating pressure up to +185° NC [bar] *
15	50 / 70	5	5.5	16
20	50 / 70	10	5.5	10 / 16
25	50 / 70 / 90	16	5.5	5 / 12 / 16
32	70 / 90	23	5.5	6 / 16
40	90	34	5.5	12
	130	36	5.5	16
50	90	49	5.5	7
	130	53	5.5	16
65	130	90	5.6	16

\* For NO (normally open) see charts on page 6

**Flow rate:**  $K_{vs}$  value water [m<sup>3</sup>/h]: Measured at +20 °C. 1 bar pressure at valve inlet and free outlet.

**Pressure valves [bar]:** Overpressure to the atmospheric pressure

## Flow characteristic

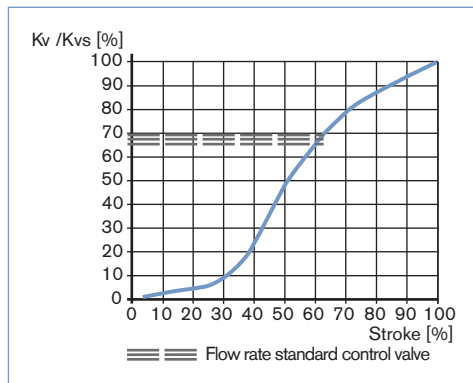

## Remarks on the flow characteristic

Modified equi-percentile flow characteristic, engineered for a quick response during peak flow demand (an advantage for many processes like heating/cooling with heat exchangers) and fine control at lower flow.

 $K_{vs}$  values [m<sup>3</sup>/h]

Orifice [mm]	Actuator size [mm]	Stroke [%]										
		5	10	20	30	40	50	60	70	80	90	100
15	50 / 70	0.16	0.17	0.22	0.4	1.2	2.7	3.5	4.0	4.5	4.8	5
20	50 / 70	0.26	0.27	0.4	1.1	4.0	5.9	7.2	8.3	9.1	9.6	10
25	50 / 70 / 90	0.34	0.36	0.62	1.5	5.2	8.9	11.5	13.0	14.2	15.4	16
32	70 / 90	0.43	0.52	0.82	1.4	4.0	9.3	13.8	16.4	19.2	21.3	23
40	90	0.47	0.62	1.1	2.6	10.0	17.0	21.5	25.3	28.8	31.6	34
	130	0.48	0.66	1.4	5.1	14.0	20.0	24.3	28.3	31.7	34.5	36
50	90	0.85	1.1	1.6	2.7	10.2	20.0	28.6	35.6	40.6	45.0	49
	130	0.87	1.2	1.8	4.0	15.2	26.0	35.0	40.3	45.0	48.0	53
65	130	1.7	2	6.5	20	35	48	58	67	75	83	90

Ordering chart Type 2300. flow direction below the seat (for gases and liquids)

Welded connection acc. to EN ISO 1127

Control function	Orifice [mm]	Actuator size Ø [mm]	Port connection tube-Ø [mm]	K <sub>vs</sub> value water [m³/h]	Operating pressure up to +185°C [bar]	Item no. plug sealing PTFE/St. st.	Leakage class	Item no. plug sealing St. st./St. st.	Leakage class
<b>A</b> 2/2-way valve. NC 	15	50	21.3 x 1.6	5	16	203 565	VI	206 250	IV
		70	21.3 x 1.6	5	16	203 566	VI	206 252	IV
	20	50	26.9 x 1.6	10	10	203 567	VI	206 253	III
		70	26.9 x 1.6	10	16	203 568	VI	206 254	IV
		90	26.9 x 1.6	10	16	203 569	VI	206 255	III
	25	50	33.7 x 2	16	5	203 569	VI	206 255	III
		70	33.7 x 2	16	12	203 570	VI	206 256	III
		90	33.7 x 2	16	16	245 395	VI	245 403	IV
	32	70	42.4 x 2	23	6	203 571	VI	206 257	III
		90	42.4 x 2	23	16	204 766	VI	245 404	IV
	40	90	48.3 x 2	34	12	203 572	VI	206 258	III
		130	48.3 x 2	36	16	223 299	VI	223 306	IV
	50	90	60.3 x 2.6	49	7	203 573	VI	206 259	III
		130	60.3 x 2.6	53	16	213 701	VI	213 711	IV
65	130	76.1 x2.3	90	16	239 490	VI	217 770	IV	
<b>B</b> 2/2-way valve. NO 	15	50	21.3 x 1.6	5	See charts on page 6	203 574	VI	223 340	IV
		70	21.3 x 1.6	5		203 575	VI	223 341	IV
	20	50	26.9 x 1.6	10		203 576	VI	223 342	III
		70	26.9 x 1.6	10		203 577	VI	223 343	IV
	25	50	33.7 x 2	16		203 578	VI	223 344	III
		70	33.7 x 2	16		203 579	VI	223 345	III
	32	70	42.4 x 2	23		203 580	VI	223 346	III
	40	90	48.3 x 2	34		203 581	VI	223 347	IV
	50	90	60.3 x 2.6	49		203 582	VI	223 348	III
	65	130	76.1 x2.3	90		239 498	VI	239 515	IV

Welded connection acc. to DIN 11850 S2

Control function	Orifice [mm]	Actuator size Ø [mm]	Port connection tube-Ø [mm]	K <sub>vs</sub> value water [m³/h]	Operating pressure up to +185°C [bar]	Item no. plug sealing PTFE/St. st.	Leakage class	Item no. plug sealing St. st./St. st.	Leakage class
<b>A</b> 2/2-way valve. NC 	15	50	19 x 1.5	5	16	203 583	VI	223 349	IV
		70	19 x 1.5	5	16	203 584	VI	223 350	IV
	20	50	23 x 1.5	10	10	203 585	VI	223 351	III
		70	23 x 1.5	10	16	203 586	VI	223 352	IV
	25	50	29 x 1.5	16	5	203 587	VI	223 353	III
		70	29 x 1.5	16	12	203 588	VI	223 354	III
		90	29 x 1.5	16	16	245 396	VI	245 409	IV
	32	70	35 x 1.5	23	6	203 589	VI	223 355	III
		90	35 x 1.5	23	16	204 767	VI	245 410	IV
	40	90	41 x 1.5	34	12	203 590	VI	223 356	III
		130	41 x 1.5	36	16	223 300	VI	223 357	IV
	50	90	53 x 1.5	49	7	203 591	VI	223 358	III
		130	53 x 1.5	53	16	213 702	VI	223 359	IV
	65	130	70 x 2	90	16	239 491	VI	239 507	IV
<b>B</b> 2/2-way valve. NO 	15	50	19 x 1.5	5	See charts on page 6	203 592	VI	223 360	IV
		70	19 x 1.5	5		203 593	VI	223 361	IV
	20	50	23 x 1.5	10		203 594	VI	223 362	III
		70	23 x 1.5	10		203 595	VI	223 363	IV
	25	50	29 x 1.5	16		203 596	VI	223 364	III
		70	29 x 1.5	16		203 597	VI	223 365	III
	32	70	35 x 1.5	23		203 598	VI	223 366	III
	40	90	41 x 1.5	34		203 599	VI	223 367	IV
	50	90	53 x 1.5	49		203 600	VI	223 368	III
	65	130	70 x 2	90		239 499	VI	239 516	IV

## Ordering chart Type 2300. flow direction below the seat (for gases and liquids). continued

## Welded connection acc. to ASME BPE

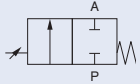
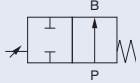
Control function	Orifice [mm]	Actuator size Ø [mm]	Port connection tube-Ø [mm]	$K_{vs}$ value water [m <sup>3</sup> /h]	Operating pressure up to +185°C [bar]	Item no. plug sealing PTFE/St. st.	Leakage class	Item no. plug sealing St. st./St. st.	Leakage class
<b>A</b> 2/2-way valve. NC 	15	50	12.7 x 1.65	5	16	203 601	VI	223 369	IV
		70	12.7 x 1.65	5	16	203 602	VI	223 370	IV
	20	50	19.05 x 1.65	10	10	203 603	VI	223 371	III
		70	19.05 x 1.65	10	16	203 604	VI	223 372	IV
		90	19.05 x 1.65	10	16	203 605	VI	223 373	III
	25	50	25.4 x 1.65	16	5	203 606	VI	223 374	III
		70	25.4 x 1.65	16	12	203 607	VI	223 375	III
		90	25.4 x 1.65	16	16	245 397	VI	245 411	IV
	40	90	38.1 x 1.65	34	12	203 607	VI	223 375	III
		130	38.1 x 1.65	36	16	223 301	VI	223 376	IV
	50	90	50.8 x 1.65	49	7	203 608	VI	223 377	III
		130	50.8 x 1.65	53	16	213 703	VI	223 378	IV
	65	130	63.5 x 1.65	90	16	239 492	VI	239 508	IV
	<b>B</b> 2/2-way valve. NO 	15	50	12.7 x 1.65	5	see charts on page 6	203 609	VI	223 379
70			12.7 x 1.65	5	203 610		VI	223 380	IV
20		50	19.05 x 1.65	10	203 611		VI	223 381	III
		70	19.05 x 1.65	10	203 612		VI	223 382	IV
25		50	25.4 x 1.65	16	203 613		VI	223 383	III
		70	25.4 x 1.65	16	203 614		VI	223 384	III
40		90	38.1 x 1.65	34	203 615		VI	223 385	IV
50		90	50.8 x 1.65	49	203 616		VI	223 386	III
65		130	63.5 x 1.65	90	239 500		VI	239 517	IV

## Welded connection acc. to SMS 3008

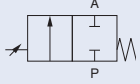
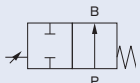
Control function	Orifice [mm]	Actuator size Ø [mm]	Port connection tube-Ø [mm]	$K_{vs}$ value water [m <sup>3</sup> /h]	Operating pressure up to +185°C [bar]	Item no. plug sealing PTFE/St. st.	Leakage class	Item no. plug sealing St. st./St. st.	Leakage class
<b>A</b> 2/2-way valve. NC 	15	50	12 x 1.0	5	16	203 617	VI	223 387	IV
		70	12 x 1.0	5	16	203 618	VI	223 388	IV
	20	50	18 x 1.0	10	10	203 619	VI	223 389	III
		70	18 x 1.0	10	16	203 620	VI	223 390	IV
		90	18 x 1.0	10	16	203 621	VI	223 391	III
	25	50	25 x 1.2	16	5	203 622	VI	223 392	III
		70	25 x 1.2	16	12	203 622	VI	223 392	III
		90	25 x 1.2	16	16	245 398	VI	245 412	IV
	40	90	38 x 1.2	34	12	203 623	VI	223 393	III
		130	38 x 1.2	36	16	223 302	VI	223 394	IV
	50	90	51 x 1.2	49	7	203 624	VI	223 395	III
		130	51 x 1.2	53	16	213 704	VI	223 396	IV
	65	130	63.5 x 1.65	90	16	239 493	VI	239 509	IV
	<b>B</b> 2/2-way valve. NO 	15	50	12 x 1.0	5	see charts on page 6	203 625	VI	223 397
70			12 x 1.0	5	203 626		VI	223 398	IV
20		50	18 x 1.0	10	203 627		VI	223 399	III
		70	18 x 1.0	10	203 628		VI	223 400	IV
25		50	25 x 1.2	16	203 629		VI	223 401	III
		70	25 x 1.2	16	203 630		VI	223 402	III
40		90	38 x 1.2	34	203 631		VI	223 403	IV
50		90	51 x 1.2	49	203 632		VI	223 404	III
65		130	63.5 x 1.65	90	239 501		VI	239 518	IV

## Ordering chart Type 2300. flow direction below the seat (for gases and liquids). continued

Welded connection acc. to BS 4825

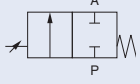
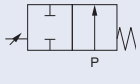
Control function	Orifice [mm]	Actuator size Ø [mm]	Port connection tube-Ø [mm]	K <sub>vs</sub> value water [m <sup>3</sup> /h]	Operating pressure up to +185°C [bar]	Item no. plug sealing PTFE/St. st.	Leakage class	Item no. plug sealing St. st./St. st.	Leakage class
<b>A</b> 2/2-way valve. NC 	15	50	12.7 x 1.2	5	16	203 633	VI	223 405	IV
		70	12.7 x 1.2	5	16	203 634	VI	223 406	IV
	20	50	19.05 x 1.65	10	10	203 635	VI	223 407	III
		70	19.05 x 1.65	10	16	203 636	VI	223 408	IV
	25	50	25.4 x 1.65	16	5	203 637	VI	223 409	III
		70	25.4 x 1.65	16	12	203 638	VI	223 410	III
		90	25.4 x 1.65	16	16	245 400	VI	245 413	IV
	40	90	38.1 x 1.65	34	12	203 639	VI	223 411	III
		130	38.1 x 1.65	36	16	223 303	VI	223 412	IV
	50	90	50.8 x 1.65	49	7	203 640	VI	223 413	III
		130	50.8 x 1.65	53	16	213 705	VI	223 414	IV
	65	130	63.5 x 1.65	90	16	239 494	VI	239 510	IV
<b>B</b> 2/2-way valve. NO 	15	50	12.7 x 1.2	5	see charts on page 6	203 641	VI	223 415	IV
		70	12.7 x 1.2	5		203 642	VI	223 416	IV
	20	50	19.05 x 1.65	10		203 643	VI	223 417	III
		70	19.05 x 1.65	10		203 644	VI	223 418	IV
	25	50	25.4 x 1.65	16		203 645	VI	223 419	III
		70	25.4 x 1.65	16		203 646	VI	223 420	III
	40	90	38.1 x 1.65	34		203 647	VI	223 421	IV
	50	90	50.8 x 1.65	49		203 648	VI	223 422	III
	65	130	63.5 x 1.65	90		239 502	VI	239 519	IV

Materials Type 2300

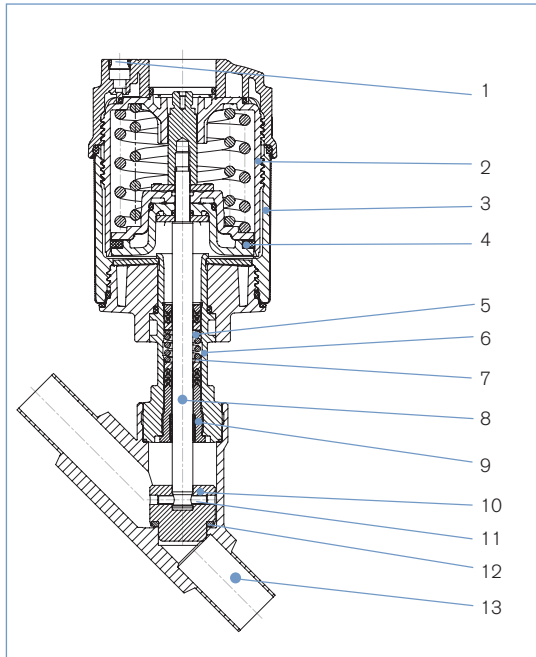

- |                               |  |
|-------------------------------|--|
| <b>1 Pilot air ports</b>      | Push-in connector PP (standard)                          |
| <b>2 Actuator</b>             | PPS  |
| <b>3 Cover</b>                | Stainless steel 1.4561 (316Ti)                           |
| <b>4 Piston seal</b>          | FKM  |
| <b>5 Spring</b>               | Stainless steel 1.4310                                   |
| <b>6 Tube</b>                 | Stainless steel 1.4401 (316) / 1.4404 (316L)             |
| <b>7 Spindle packing</b>      | PTFE   |
| <b>8 Spindle</b>              | Stainless steel 1.4401 (316) / 1.4404 (316L)             |
| <b>9 Spindle guidance</b>     | Edelstahl 1.4404 (316L)                                  |
| <b>10 Plug</b>                | Stainless steel 1.4571                                   |
| <b>11 Spring straight pin</b> | Stainless steel 1.4310                                   |
| <b>12 Plug seal</b>           | Stainless steel 1.4571 / PTFE disc for soft seat sealing |
| <b>13 Valve body</b>          | Stainless steel 316L                                     |

Pressure Charts with control function B (normally open. NO)

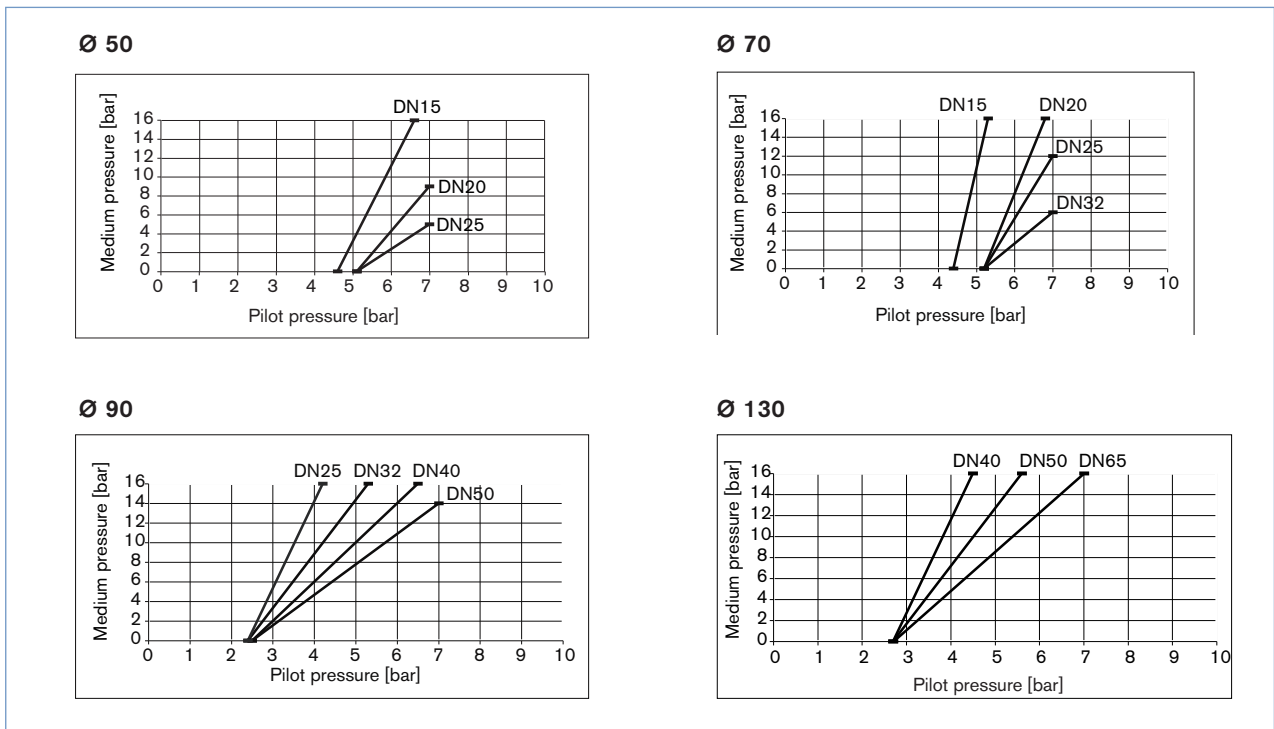

**Ordering information for valve system Continuous ELEMENT Type 8802-YG**

A **valve system Continuous ELEMENT Type 8802-YG** consists of an angle-seat control valve **Type 2300** and a digital electropneumatic Positioner **Type 8692**, a digital electropneumatic Process Controller **Type 8693**, a digital electropneumatic Positioner Basic **Type 8694** (below), an electropneumatic Positioner **Type 8792/8793** (for valve actuator sizes  $\varnothing$  70/90/130 mm) or a digital electropneumatic Positioner **Type 8696** (for valve actuator size  $\varnothing$  50 mm) (see next page and separate datasheets). For the configuration of further valve systems please use the "Request for quotation" on p. 13 [go to page](#)

You order two components and receive a complete assembled and certified valve.

**Ordering the valve system Continuous ELEMENT Type 8802-YG**

**Angle seat valve Type 2300**



**Positioner**



Positioner  
Type 8692



Process Controller  
Type 8693



Positioner Basic  
Type 8694

**Angle seat valve  
with desired control unit**



Valve system  
Continuous  
ELEMENT  
Type 8802-YG-I  
2300 + 8692



Valve system  
Continuous  
ELEMENT  
Type 8802-YG-J  
2300 + 8693



Valve system  
Continuous  
ELEMENT  
Type 8802-YG-L  
2300 + 8694

When you click on the orange box "More info." below, you will come to our website for the resp. product where you can download the datasheet.

**Positioner TopControl  
Type 8692**

More  
info.



**Process Controller  
TopControl Type 8693**

More  
info.



The new generation of integrated positioners/process controllers for combination with actuators from the process valve series Type 23xx/2103 is specially designed for the requirements of hygienic process environments. The easy handling and the selection of additional software functions are done either on a big graphic display with backlight and keypad or via a PC interface. A contact-free analogue position sensor registers the valve position without deterioration. Single-acting or double-acting actuators are controlled via the integral positioner system. With Type 8693, the process controller function is superimposed on the position control loop. Profibus DPV1 and DeviceNet communication interfaces are available as options.

Main customer benefits:

- Compact design of the valve system with integrated positioner/process controller meets the demands for plant washdown environments through the selection of materials, external seals and integrated control air supply to the actuator
- Extremely simple commissioning and operation thanks to the backlighting of the graphics display and proven multilingual software structure
- Automatic parameterisation of the positioner and process controller using the TUNE functions
- Field bus communication via Profibus DPV1 or DeviceNet
- Air intake filter enhances the process valve system availability
- Simple and reliable actuator adaption

**Positioner TopControl Basic Type 8694**

More  
info.



The new generation of integrated positioners for combination with actuators from the process valve series Type 23xx/2103 is specially designed for the requirements of hygienic process environments. The operation and selection of the software functions close tight function, inversion of the operating direction of the setpoint signal, characteristic curves selection and switching manual/automatic operation are effected via push-buttons and DIP switches or via the PC interface. The position setpoint is set using the standard signal 4 - 20 mA. In addition, the enable can be controlled via the binary input and an optional position feedback can be integrated. The positioner, Type 8694, registers the valve position without deterioration through a contact-free analogue position sensor. Single-acting or double-acting actuators are controlled via the integral positioner system. An AS-Interface communication interface is available as an option.

Main customer benefits:

- Compact design of the valve system with integrated positioner meets the demands for plant washdown environments through the selection of materials, external seals and integrated control air supply to the actuator
- Automatic parameterisation of the positioner using the Process TUNE function
- Field bus communication via optional AS-Interface
- Air intake filter enhances the process valve system availability
- Simple and reliable actuator adaption allowing additional actuators of the process valve series, Type 20xx or actuators from other manufacturers to be used

**Ordering information for valve system Continuous ELEMENT Type 8802-YG. continued**

A valve system Continuous ELEMENT Type 8802-YG consists of an angle-seat control valve Type 2300 and a digital electropneumatic Positioner Type 8692, a digital electropneumatic Process Controller Type 8693, a digital electropneumatic Positioner Basic Type 8694 (previous page), an electropneumatic Positioner Type 8792/8793 (for valve actuator sizes  $\varnothing$  70/90/130) mm or a digital electropneumatic Positioner Type 8696 (for valve actuator size  $\varnothing$  50 mm) (see separate datasheets). For the configuration of further valve systems please use the "Request for quotation" on p. 13 [go to page](#)

You order two components and receive a complete assembled and certified valve.

**Ordering the valve system Continuous ELEMENT Type 8802-YG**

**Angle seat valve Type 2300**



**Positioner**



Positioner  
Type 8792/  
Process Controller Type 8793



TopControl Basic Type 8696  
Only for actuator size  
 $\varnothing$  50 mm

**Angle seat valve  
with desired control unit**



Valve system  
Continuous ELEMENT  
Type 8802-YG-P  
2300 + 8792 /  
Type 8802-YG-Q  
2300 + 8793



Valve system  
Continuous ELEMENT  
Type 8802-YG-N  
2300 + 8696

When you click on the orange box "More info." below, you will come to our website for the resp. product where you can download the datasheet.

**Positioner SideControl Type 8792**

More info.

**Process Controller SideControl Type 8793**

More info.



Type 8792/8793 is a digital electro-pneumatic positioner with an optional, integrated process controller (8793) for precise control requirements. The compact design with integrated position encoder and LCD display was developed for demanding applications of the process industry. A Profibus DPV1 communication interface is available as an option. Main customer benefits are:

- Time saving algorithms for temperature, flow and pressure PID parameters through ProcessTUNE function.
- Quick and simple menu driven parameterization through keyboard or Profibus DPV1 PA
- Adaption acc. to IEC534-6 and VDI/VDE 3845 for lift and swivel drives or as a Remote version together with Bürkert process valves
- Rugged anodised aluminium housing

**TopControl Basic Type 8696**

Mehr Infos



The new generation of integrated positioners for combination with small actuators from the process valve series Type 23xx/2103 is specially designed for the requirements of hygienic process environments. The operation and selection of the software functions close tight function, inversion of the operating direction of the setpoint signal, characteristic curves selection and switching manual/automatic operation are effected via push-buttons and DIP switches or via the PC interface. The position setpoint is set using the standard signal 4 - 20 mA. In addition, the enable can be controlled via the binary input and an optional position feedback can be integrated. The positioner, Type 8696, registers the valve end position without deterioration through a contact-free analogue position sensor. Single-acting actuators are controlled via the integral positioner system. Main customer benefits:

- Compact design of the valve system with integrated positioner meets the demands for plant washdown environments through the selection of materials, external seals and integrated control air supply to the actuator
- Automatic parameterisation of the positioner using the TUNE function
- Simple and reliable actuator adaption



Dimensions for valve system Continuous ELEMENT Type 8802-YG [mm]

Dimensions valve system Continuous ELEMENT Type 8802-YG-I with positioner TopControl Type 8692 or 8802-YG-J with process controller TopControl Type 8693 [mm]

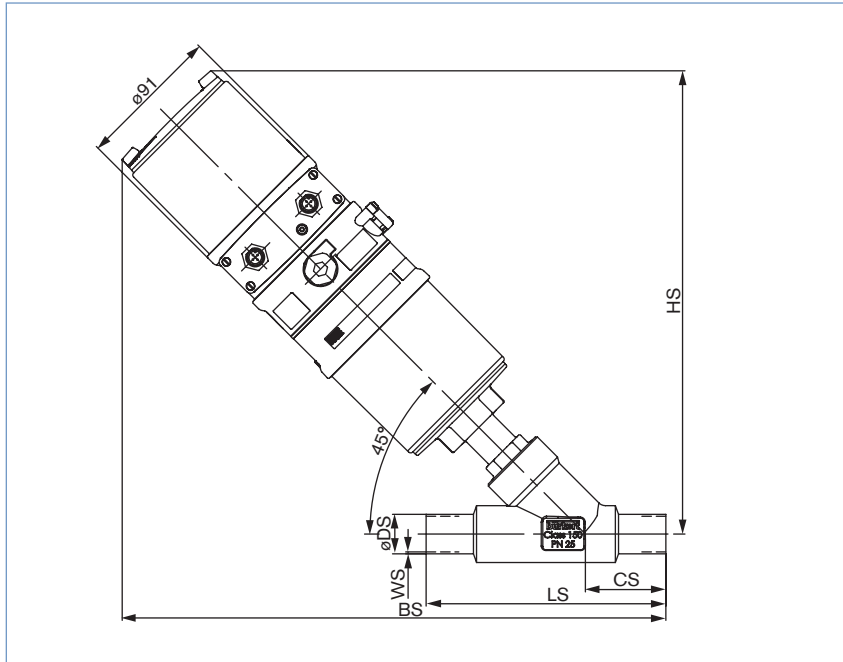

ISO 4200, DIN 11850 R2, ASME BPE

Orifice [mm]	Actuator size [mm]	HS	ISO 4200					DIN 1180 R2					ASME BPE				
			BS	CS	LS	øDS	WS	BS	CS	LS	øDS	WS	BS	CS	LS	øDS	WS
15	70	285	323	34	100	21.3	1.6	323	34	100	19	1.5	323	34	100	12.7	1.65
20	70	293	335	39	115	26.9	1.6	335	39	115	23	1.5	335	39	115	19.05	1.65
25	70	295	341	43	130	33.7	2	341	43	130	29	1.5	341	43	130	25.4	1.65
	90	332	376	43	130	33.7	2	376	43	130	29	1.5	376	43	130	25.4	1.65
32	70	304	348	40	145	42.4	2	348	40	145	35	1.5	-	-	-	-	-
	90	347	388	40	145	42.4	2	388	40	145	35	1.5	-	-	-	-	-
40	90	350	401	49	160	48.3	2	401	49	160	41	1.5	401	49	160	38.1	1.65
	130	387	436	49	160	48.3	2	436	49	160	41	1.5	436	49	160	38.1	1.65
50	90	366	417	50	175	60.3	2.6	417	50	175	53	1.5	417	50	175	50.8	1.65
	130	403	453	50	175	60.3	2.6	453	50	175	53	1.5	453	50	175	50.8	1.65
65	130	433	483	50	210	76.1	2.3	483	50	210	70	2	483	56	230	63.5	1.65

SMS 3008, BS4825

Orifice [mm]	Actuator size [mm]	HS	SMS 3008					BS 4825				
			BS	CS	LS	øDS	WS	BS	CS	LS	øDS	WS
15	70	285	335	46	135	12	1	323	34	100	12.7	1.2
20	70	293	348	52	145	18	1	335	39	115	19.05	1.2
25	70	295	349	51	152	25	1.2	341	43	130	25.4	1.65
	90	332	384	51	152	25	1.2	376	43	130	25.4	1.65
40	90	350	412	60	182	38	1.2	401	49	160	38.1	1.65
	130	387	447	60	182	38	1.2	436	49	160	38.1	1.65
50	90	366	431	64	210	51	1.2	417	50	175	50.8	1.65
	130	403	467	64	210	51	1.2	453	50	175	50.8	1.65
65	130	433	489	56	230	63.5	1.65	483	56	230	63.5	1.65

Dimensions for valve system Continuous ELEMENT Type 8802-YG [mm]. continued

Dimensions valve system Continuous ELEMENT Type 8802-YG-L with positioner TopControl Basic Type 8694 [mm]

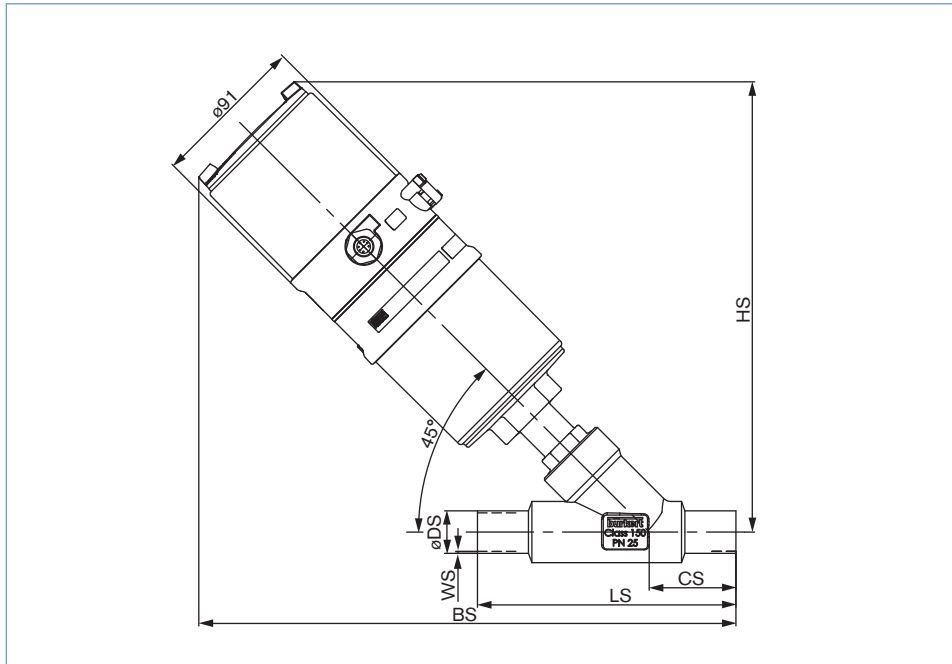

ISO 4200, DIN 11850 R2, ASME BPE

Orifice [mm]	Actuator size	HS	ISO 4200					DIN 1180 R2					ASME BPE				
			BS	CS	LS	øDS	WS	BS	CS	LS	øDS	WS	BS	CS	LS	øDS	WS
15	70	256	294	34	100	21.3	1.6	294	34	100	19	1.5	294	34	100	12.7	1.65
20	70	264	306	39	115	26.9	1.6	306	39	115	23	1.5	306	39	115	19.05	1.65
25	70	266	312	43	130	33.7	2	312	43	130	29	1.5	312	43	130	25.4	1.65
	90	303	347	43	130	33.7	2	347	43	130	29	1.5	347	43	130	25.4	1.65
32	70	275	319	40	145	42.4	2	319	40	145	35	1.5	-	-	-	-	-
	90	318	359	40	145	42.4	2	359	40	145	35	1.5	-	-	-	-	-
40	90	321	372	49	160	48.3	2	372	49	160	41	1.5	372	49	160	38.1	1.65
	130	358	407	49	160	48.3	2	407	49	160	41	1.5	407	49	160	38.1	1.65
50	90	337	388	50	175	60.3	2.6	388	50	175	53	1.5	388	50	175	50.8	1.65
	130	374	424	50	175	60.3	2.6	424	50	175	53	1.5	424	50	175	50.8	1.65
65	130	404	454	50	210	76.1	2.3	454	50	210	70	2	454	56	230	63.5	1.65

SMS 3008, BS 4825

Orifice [mm]	Actuator size	HS	SMS 3008					BS 4825				
			BS	CS	LS	øDS	WS	BS	CS	LS	øDS	WS
15	70	256	306	46	135	12	1	294	34	100	12.7	1.2
20	70	264	319	52	145	18	1	306	39	115	19.05	1.2
25	70	266	320	51	152	25	1.2	312	43	130	25.4	1.65
	90	303	355	51	152	25	1.2	347	43	130	25.4	1.65
40	90	321	383	60	182	38	1.2	372	49	160	38.1	1.65
	130	358	418	60	182	38	1.2	407	49	160	38.1	1.65
50	90	337	402	64	210	51	1.2	388	50	175	50.8	1.65
	130	374	438	64	210	51	1.2	424	50	175	50.8	1.65
65	130	404	460	56	230	63.5	1.65	454	56	230	63.5	1.65

Dimensions for valve system Continuous ELEMENT Type 8802-YG [mm]. continued

Dimensions valve system Continuous ELEMENT Type 8802-YG-P with positioner SideControl Remote Type 8792 and Type 8802-YG-Q with Process Controller SideControl Remote Type 8793 [mm]

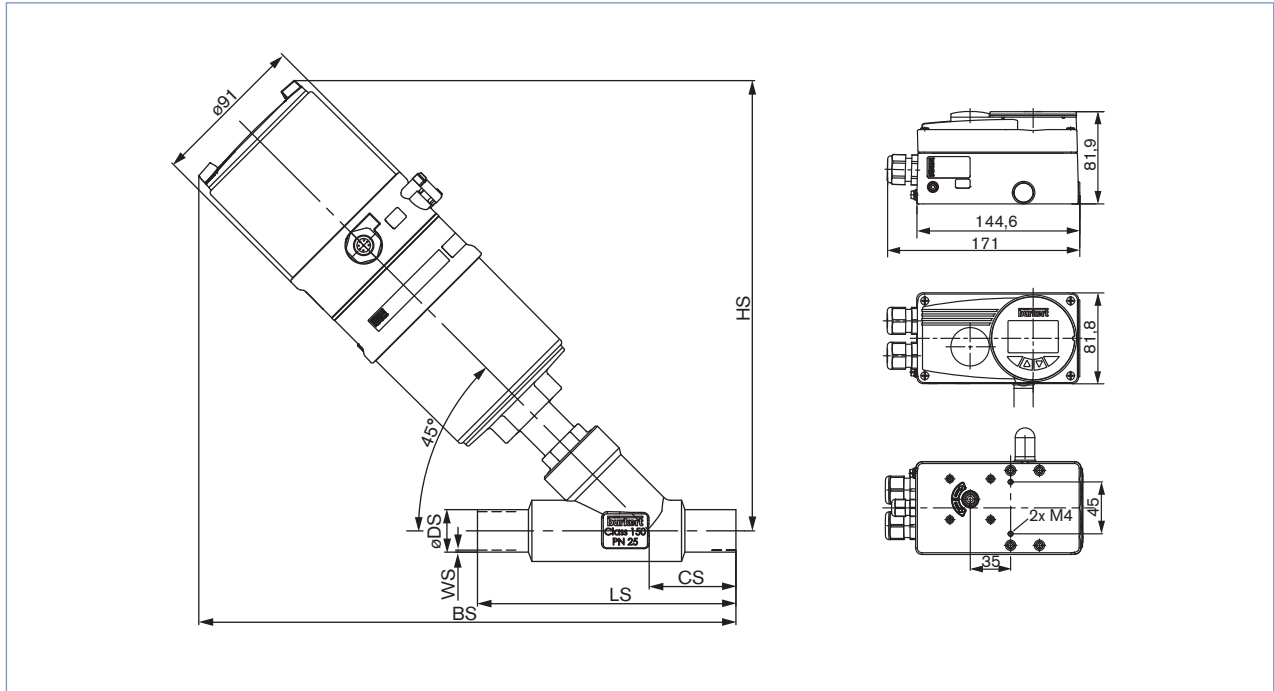

ISO 4200, DIN 11850 R2, ASME BPE,

Orifice [mm]	Actuator size	HS	ISO 4200					DIN 1180 R2					ASME BPE				
			BS	CS	LS	øDS	WS	BS	CS	LS	øDS	WS	BS	CS	LS	øDS	WS
15	70	256	294	34	100	21.3	1.6	294	34	100	19	1.5	294	34	100	12.7	1.65
20	70	264	306	39	115	26.9	1.6	306	39	115	23	1.5	306	39	115	19.05	1.65
25	70	266	312	43	130	33.7	2	312	43	130	29	1.5	312	43	130	25.4	1.65
	90	303	347	43	130	33.7	2	347	43	130	29	1.5	347	43	130	25.4	1.65
32	70	275	319	40	145	42.4	2	319	40	145	35	1.5	-	-	-	-	-
	90	318	359	40	145	42.4	2	359	40	145	35	1.5	-	-	-	-	-
40	90	321	372	49	160	48.3	2	372	49	160	41	1.5	372	49	160	38.1	1.65
	130	358	407	49	160	48.3	2	407	49	160	41	1.5	407	49	160	38.1	1.65
50	90	337	388	50	175	60.3	2.6	388	50	175	53	1.5	388	50	175	50.8	1.65
	130	374	424	50	175	60.3	2.6	424	50	175	53	1.5	424	50	175	50.8	1.65
65	130	404	454	50	210	76.1	2.3	454	50	210	70	2	454	56	230	63.5	1.65

SMS 3008, BS 4825

Orifice [mm]	Actuator size	HS	SMS 3008					BS 4825				
			BS	CS	LS	øDS	WS	BS	CS	LS	øDS	WS
15	70	256	306	46	135	12	1	294	34	100	12.7	1.2
20	70	264	319	52	145	18	1	306	39	115	19.05	1.2
25	70	266	320	51	152	25	1.2	312	43	130	25.4	1.65
	90	303	355	51	152	25	1.2	347	43	130	25.4	1.65
40	90	321	383	60	182	38	1.2	372	49	160	38.1	1.65
	130	358	418	60	182	38	1.2	407	49	160	38.1	1.65
50	90	337	402	64	210	51	1.2	388	50	175	50.8	1.65
	130	374	438	64	210	51	1.2	424	50	175	50.8	1.65
65	130	404	460	56	230	63.5	1.65	454	56	230	63.5	1.65

**Dimensions for valve system Continuous ELEMENT Type 8802-YG [mm]. continued**

**Dimensions valve system Continuous ELEMENT Type 8802-YG-N with positioner TopControl Basic Type 8696 [mm]**

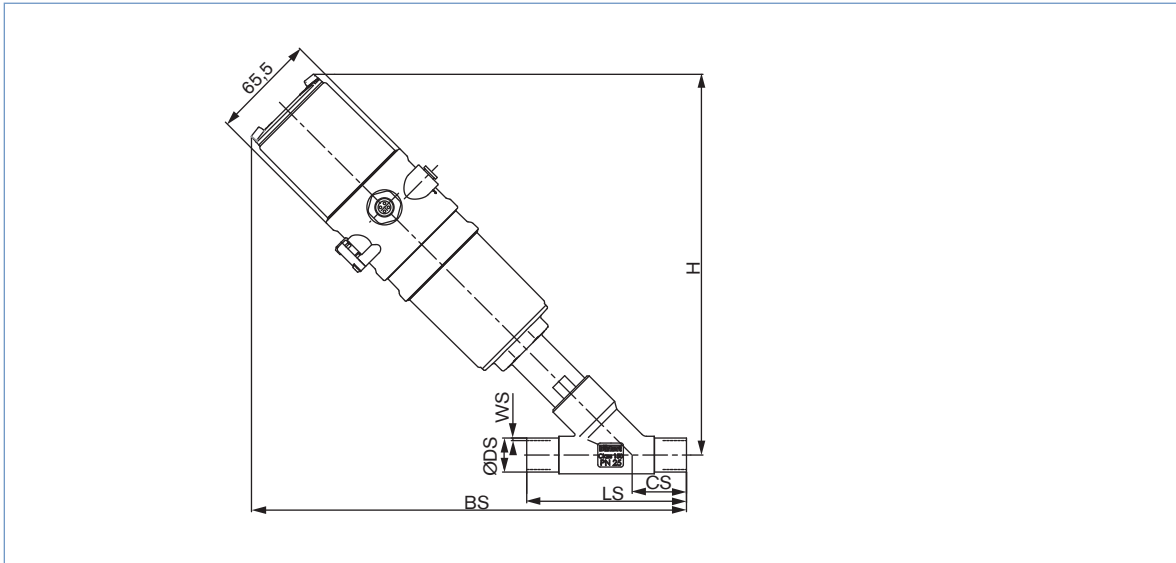

**ISO 4200, DIN 11850 R2, ASME BPE**

Orifice [mm]	Actuator size	HS	ISO 4200					DIN 1180 R2					ASME BPE				
			BS	CS	LS	øDS	WS	BS	CS	LS	øDS	WS	BS	CS	LS	øDS	WS
15	50	239	276	34	100	21.3	1.6	276	34	100	19	1.5	276	34	100	12.7	1.65
20	50	247	288	39	115	26.9	1.6	288	39	115	23	1.5	288	39	115	19.05	1.65
25	50	248	294	43	130	33.7	2	294	43	130	29	1.5	294	43	130	25.4	1.65

**SMS 3008 , BS4825**

Orifice [mm]	Actuator size	HS	SMS 3008					BS 4825				
			BS	CS	LS	øDS	WS	BS	CS	LS	øDS	WS
15	50	239	288	46	135	12	1	276	34	100	12.7	1.2
20	50	247	301	52	145	18	1	288	39	115	19.05	1.2
25	50	248	302	51	152	25	1.2	294	43	130	25.4	1.65

**Note**

You can fill out the fields directly in the PDF file before printing out the form.

**Valve system Continuous ELEMENT Type 8802-YG - Request for quotation**

▶ Please fill out and send to your nearest Bürkert facility\* with your inquiry or order

Company	Contact person
Customer no.	Department
Address	Tel./Fax
Postcode/town	E-mail

= mandatory fields to fill out       Quantity       Required delivery date

**Operating data**

Pipe line	DN	<input type="text"/>	PN	<input type="text"/>
Pipe material	<input type="text"/>			
Process medium	<input type="text"/>			
Type of medium	<input type="checkbox"/> Liquid	<input type="checkbox"/> Steam	<input type="checkbox"/> Gas	
Flow rate (Q, Q <sub>N</sub> , W) <sup>1)</sup>	min	standard	max	unit
Temperature at valve inlet T1	<input type="text"/>	<input type="text"/>	<input type="text"/>	<input type="text"/>
Absolute pressure at valve inlet P1	<input type="text"/>	<input type="text"/>	<input type="text"/>	<input type="text"/>
Absolute pressure at valve outlet P2	<input type="text"/>	<input type="text"/>	<input type="text"/>	<input type="text"/>
Steam pressure P <sub>v</sub>	<input type="text"/>	<input type="text"/>	<input type="text"/>	<input type="text"/>
Kinematic viscosity (ν)	<input type="text"/>	mm <sup>2</sup> /s or cSt		
Dynamic viscosity (η)	<input type="text"/>	mPa.s or cP		
Standard density	<input type="text"/>	Kg/m <sup>3</sup>		
Max. sound level accepted	<input type="text"/>	dB (A)		

<sup>1)</sup> standard unit: Liquid Q = m<sup>3</sup>/h; Steam W = kg/h; Gas Q<sub>N</sub> = Nm<sup>3</sup>/h

**Valve features**







Plug seal material	<input type="checkbox"/> PTFE/Stainless steel	<input type="checkbox"/> Stainless steel/Stainless steel	
Nominal pressure	PN	<input type="text"/>	
Orifice	DN	<input type="text"/>	
Type of connection	<input type="checkbox"/> Threaded	<input type="checkbox"/> Welded	<input type="checkbox"/> Clamp
Standard connection	<input type="checkbox"/> ISO	<input type="checkbox"/> DIN	<input type="checkbox"/> Other <input type="text"/>
Control function	<input type="checkbox"/> NC <sup>2)</sup>	<input type="checkbox"/> NO <sup>2)</sup>	
Please specify item no. if known:	<input type="text"/>		

<sup>2)</sup> NC: normally closed by spring action; NO: normally open by spring action

**Comments**

\* To find your nearest Bürkert facility. click on the orange box → [www.burkert.com](http://www.burkert.com)

Valve system Continuous ELEMENT Type 8802-YG - Request for quotation. continued

Control unit features		
For actuator sizes 70/90/130 mm		
<input type="checkbox"/> Positioner TopControl Type 8692  <input type="checkbox"/> Process Controller TopControl Type 8693 	<input type="checkbox"/> Positioner TopControl Basic Type 8694 	<input type="checkbox"/> Positioner SideControl Remote Type 8792  <input type="checkbox"/> Process Controller SideControl Remote Typ 8793 
<p><b>Pneumatic function</b></p> <input type="checkbox"/> Single-acting <input type="checkbox"/> Double-acting <p><b>Communication</b></p> <input type="checkbox"/> Profibus <input type="checkbox"/> DeviceNet <p><b>Electrical connection</b></p> <input type="checkbox"/> Cable gland <input type="checkbox"/> Multipol connection <p><b>Feedback</b></p> <input type="checkbox"/> 4-20 mA <input type="checkbox"/> 4-20 mA + 2 binary outputs <p><b>Initiator</b></p> <input type="checkbox"/> Initiator <p>Please specify item no. if known: <input type="text"/></p>	<p><b>Pneumatic function</b></p> <input type="checkbox"/> Single-acting <p><b>Pilot air ports</b></p> <input type="checkbox"/> Push-in connector external ø 6 mm or 1/4" <input type="checkbox"/> Thread G 1/8" <p><b>Electrical connection</b></p> <input type="checkbox"/> Cable gland <input type="checkbox"/> Multipol connection <p><b>Feedback</b></p> <input type="checkbox"/> 4-20 mA <p>Please specify item no. if known: <input type="text"/></p>	<p><b>Power supply</b> 24 VDC</p> <p><b>Communication</b></p> <input type="checkbox"/> Without <input type="checkbox"/> Profibus DPV1 <p><b>Feedback</b></p> <input type="checkbox"/> Analogue feedback + 2 binary outputs <input type="checkbox"/> 2 binary outputs <p><b>Electrical connection</b></p> <input type="checkbox"/> Cable gland <input type="checkbox"/> Multipol connection <p>Please specify item no. if known: <input type="text"/></p>
For actuator size 50 mm		
<input type="checkbox"/> Positioner TopControl Basic Typ 8696 		
<p><b>Pneumatic function</b></p> <input type="checkbox"/> Single-acting <p><b>Pilot air ports</b></p> <input type="checkbox"/> Push-in connector external ø 6 mm or 1/4" <input type="checkbox"/> Thread G 1/8" <p><b>Feedback</b></p> <input type="checkbox"/> 4-20 mA <p>Please specify item no. if known: <input type="text"/></p>		

DTS 1000112034 EN Version: K Status: RL (released | freigegeben | valide) printed: 29.08.2013